

# UNIT 1

## HIGH SPEED NETWORKS

### 1. Compare packet switching (X.25) and frame relay network.

Packet switching	Frame relay
✓ Hop by Hop flow and error control	✓ End to End flow and error control
✓ Multiplexing and switching done in layer 3	✓ Multiplexing and switching operations are done in layer 2
✓ Inband signalling	✓ Common channel signalling
✓ Data rate 64 kbps	✓ Data rate 2 mbps

### 2. What is meant by common channel signalling and inband signalling?

Common channel signaling : The data and control signals of a user are transmitted on separate channel.

The control signal of all the user are passed through a signal common channel.

In channel signaling :the data and control signal of a user are transmitted on same channel. They are two types

1. In band signaling

2. out of band signalling

In band signaling : If data and control signals traveling in same channel have same frequency then it is in band signalling.

out of band signaling : If data and control signals traveling in same channel with different frequency then it is out band signalling.

### 3. Define cell sequence integrity?

It is the characteristic of virtual channel to preserve sequence of transmitted cells.

### 4. What is meant by meta signalling channel?

This channel is used to setup a virtual channel that can be used for call control.

**5. What is the purpose of cell lose priority bit in ATM cell format?**

It provides guidance to the network in the event of congestion. A value of 0 indicates a cell of relatively higher priority which should not be discarded unless no other alternative is available . a value of 1 indicates that this cell is subject to discard with in the network.

**6. What is the purpose of Pay load type field in ATM cell format?**

It is 3 bit information . it indicates type of data in information field . The first bit indicates whether it is user data or network management data, second bit indicates whether it experience congestion or not , third bit indicate SDU type .

**7. What are the AAL services?**

- ✓ Handling of transmission errors.
- ✓ Segmentation and reassembly to enable large blocks of data to be carried in the information field of ATM cell.
- ✓ Handling of lost and misinserted cell condition .
- ✓ Flow control and timing control.

**8. What are the two types of sublayer used in ATM adaptation layer?**

1. Convergence sublayer
2. Segmentation and reassembly sublayer.

**9. Define cell lose ratio?**

It is defined as the fraction of cells lost during the transmission.

**10. Define cell transfer delay?**

It is the average time needed for a cell to travel from source to destination.

**11. Define cell delay variation tolerance?**

It is a measure of variation in cell transmission time.

**12. Define Sustainable cell rate?**

The SCR is an average cell rate over a long time interval. the actual cell rate may be lower or higher than this value , but the average should be equal to or less than SCR.

**13. Define Peak cell rate?**

The PCR defines the senders maximum cell rate . The users cell rate can some time reach this pack as long as the SCR is maintained.

**14. Define minimum cell rate?**

It is minimum cell rate acceptable that a sender guranteed to send.

**15. Define cell error ratio?**

It defines the fraction of the cell delivered in error.

**16. Draw IEEE 802.3 MAC frame format.**

preamble	SFD	DSTaddr	SRC addr	PDU	Data & Padding	CRC
----------	-----	---------	-------------	-----	-------------------	-----

**17. Define fabric in fiber channel communication?**

The fiber channel communication network consists of one or more switching elements Which are collectively called as fabrics

**18. Define collision domain?**

The maximum distance that data can travel beween two stations is called collision domain in Ethernet.

**19. What is meant by adhoc networking?**

An adhoc network is a peer to peer network setup temporarily to some immediate need.

**20. What are the different types of service categories available in ATM?**

ATM service categories

Real time service

- Constant bit rate
- variable bit rate

Non Real time service

- Constant bit rate
- variable bit rate
- Available bit rate
- Unspecified bit rate

**PART – B**

1. Explains the Frame relay architecture & compare it with x.25. (16)
2. a. Explain the ATM cell with a suitable diagram and explain Generic FlowControl and Header error control. (8)  
b. Explain various ATM services. (8)
3. a. Discuss and compare the CPCS-PDU & SAR-PDU of AAL 3/4 & AAL 5 (8)  
b. Explain the architecture of AAL 1 (8)
4. Explain the architecture of 802.11 (16)
5. Explain the following:
  - a. Fast Ethernet (8)
  - b. gigabit Ethernet (8)

**UNIT 2**

**CONGESTION AND TRAFFIC MANAGEMENT**

- 1. When queue will be formed in a network?**

Queue will be formed , if the current demand for a particular service exceeds the capacity of the service provider.

## **2. What are the characteristic of queuing process?**

Characteristic of queuing process depends on :

1. Arrival pattern
2. Service pattern
3. Number of server
4. System capacity
5. Queue discipline

## **3. Define access rate?**

For every connection in frame relay network , an access rate is defined. The access rate actually depends on bandwidth of channel connecting user to network.

## **4. Define excess Burst size(Be)?**

This is maximum number of bits in excess of Bc that a user can send during a predefined period of time. The network is committed to transfer these bits if there is no congestion. Frames with Be have lower probability to transfer than frames with Bc.

## **5. Define committed information rate(CIR)**

CIR is a rate in bps that a network agrees to support for a particular frame mode connection .Any data transmitted in excess of CIR is vulnerable to discard in event of congestion

$$\text{CIR} < \text{Access rate}$$

## **6. Define committed burst size?**

This is maximum number of bits in a predefined period of time that the network is committed to transfer with out discarding any frames.

## **7. What is meant by implicit congestion signaling?**

When network congestion occurs, packets get discard and acknowledgement will be delayed. As a result , source understand that there is congestion implicitly. Here , users are notified about congestion indirectly.

## **8. What is meant by explicit congestion signaling?**

In this method congestion is indicated directly by a notification. The notification may be in backward or forward direction.

**9. What is meant by Congestion avoidance and congestion recovery technique?**

**Congestion avoidance:** It is the procedure used at beginning stage of congestion to minimize its effort.

**Congestion recovery:** Here the dropped frames are reported to higher layer and further packet delivery is stopped to recover from congestion.

**10. Draw single server queue model?**

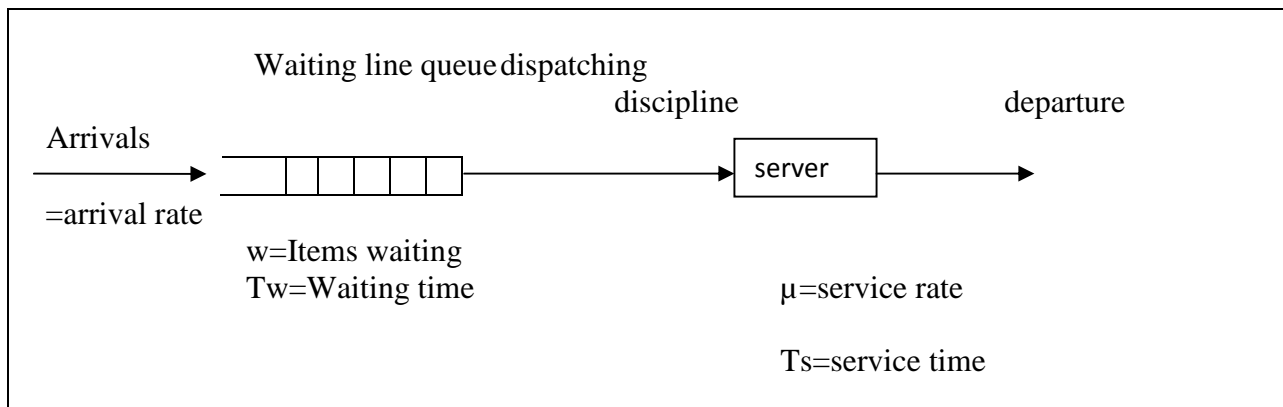

**11. Draw multiple server queue model?**

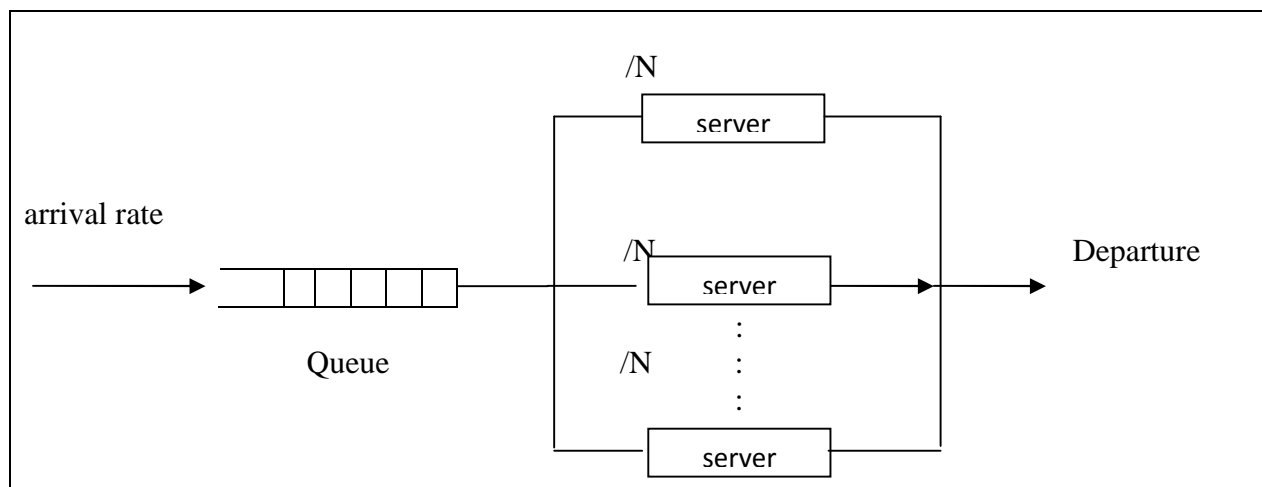

**12. Compare single server and multi server queue**

Single server Model	Multi server model
Congestion statistics for this Model are: M/M/1, M/D/1, M/G/1	Congestion statistics for this Model is M/M/N
Arrival rate =	Arrival rate for each server = $\lambda/N$

**13. Draw multiple single server queue model**

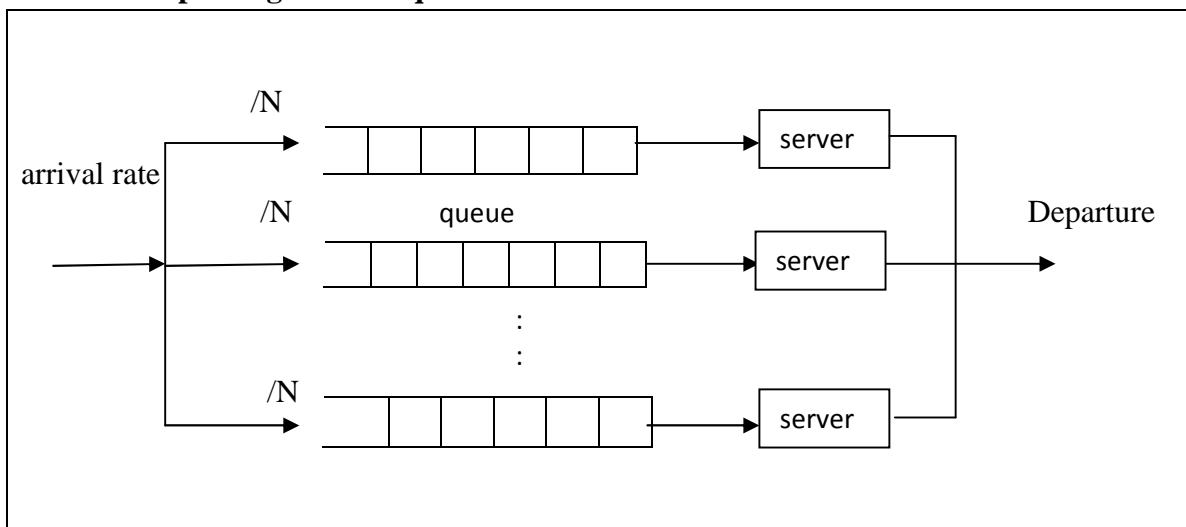

**14. What is Backward Explicit Congestion Notification?**

BECN bit warn sender , that congestion is present in opposite direction. So sender will wait for response from receiver and reduce data rate accordingly.

**15. What is Forward Explicit Congestion Notification?**

FECN bit warn the receiver of frame about congestion in network. It is then informed to higher level to delay the acknowledgement signal and this forcing the sender to slow down.

**16. Define Traffic control management?**

If user does not respond to congestion notices, then frame relay network has to discard frames. this method is called Traffic control management.

**17. What are the two types of Queue model?**

1. Single server queue
2. Multiple server queue

**18. What is meant by traffic intensity in queuing analysis?**

$$\text{Traffic intensity} = \text{Arrival rate} / \text{rate service}$$
$$= \lambda / \mu$$

**19. Write Kendall's notation**

(a/b/c) : (d/e) is Kendall's notation

a=Distribution of inter arrival time

b=distribution of service time

c= number of server

d=Maximum number of allowed items

e=queuing discipline used

**20. what is coefficient of variation?**

The ratio of standard deviation of service time and mean service time is called coefficient of variation

$$\sigma_s / \bar{s} = \text{coefficient of variation}$$

**PART – B**

**1. Explain the single- server and multi server queering models. (16)**

**2. a.Explain the effects of congestion. (8)**

**b. Explain the congestion control mechanisms in networks. (8)**

**3.Explain the effect of congestion and congestion control mechanism in packet switching network?(16)**

**4.Explain in detail about congestion control mechanism in frame relay network and its traffic control management?(16)**

**5.Explain in detail Queuing analysis? What are the Types of queuing models?**

## **UNIT-3(TCP & ATM CONGESTION CONTROL)**

### **PART-A**

#### **1. Define Fair Buffer Allocation?**

FBA: A proposed enhancement to EPD to increase fairness is known as Fair Buffer Allocation.

#### **2. Define traffic Policing?**

It occurs when a flow of data is regulated so that cells that exceed a certain performance level are discarded or tagged.

#### **3. Define Traffic Shaping?**

It is used to smooth out a traffic flow and reduce cell clumping. This results in a fairer allocation of resources and a reduced average delay time.

#### **4. What are the parameters characterized by an ABR connections?**

- (1) Allowed Cell Rate
- (2) Minimum Cell Rate
- (3) Peak Cell Rate
- (4) Initial Cell Rate

#### **5. What is the need for using window scale factor?**

For optical (SDH) link operating at 155Mbps between two distant points window scale factor can be used to improve the potential throughput.

#### **6. What are the policies implemented in TCP?**

- i. Send policy
- ii. Accept policy
- iii. Deliver policy
- iv. Retransmit policy

v.Acknowledge policy

**7.Define exponential averaging?**

A technique for predicting the next value on the basis of a time series of past values is called exponential averaging.

**8.What are the protocols that are used for the the implementation of TCP/IP over ATM?**

i.TCP

ii.IP

iii.AAL5

iv.ATM

**9.What is partial packet discard?**

If a cell from an IP datagram is dropped from a switch buffer then the subsequent cells in that datagram are also discarded.

**10.What are the four ATM attributes?**

i.Traffic Descriptors.

ii.QOS parameters.

iii.Congestion

iv.Other attributes for UBR

**11.Define cell loss ratio?**

The cell loss ratio is the ratio of the lost cells to total transmitted cells on a connection.

**12.What are the techniques to manage the send window?**

(i)Slow Start

(ii)Dynamic Window sizing on congestion

(iii)Fast retransmit

(iv)Fast recovery

(v)Limited transmit

**13.What is conformance definition?**

The conformance definition is used to unambiguously specify the conforming cells of a connection at the user network interface(UNI).The Generic Cell Rate Algorithm is used to define conformance

**14.How can the cell delay variation can be minimized?**

The cell delay variation can be reduced by increasing the data rate at the user network interface(UNI) relative to the load and by increasing within the network.

**15.What are the two general options for allocating capacity to the VPC?**

- (i)Aggregate peak demand
- (ii)Statistical Multiplexing

**16.Define fairshare?**

The fairshare is defined as the ratio of target time to the available number of connections.

**17.What are the two functions encompassed by usage parameter control(UPC)?**

- (1)Control of peak cell rate andt he associated CDTV
- (2)control of sustainable cell rate and the associated burst tolerance

**18.What are the three basic approaches that can be used by the network to provide per –ve gurantees for GFR ?**

- i.Tagging and policing
- ii.Buffer management
- iii.Scheduling

**19.Wat are the response time which traffic operate?**

- i.Cell Insertion Time
- ii.Round trip propagation time
- iii.Connection duration
- iv.Long term

**20. What is known as BACK off Process ?**

TCP sources increase its Retransmission timer (RTO) each time the same segment is retransmitted.

**PART –B**

- 1. Describe in detail about TCP flow control and congestion control ?**
- 2. Explain about the window management techniques?**
- 3. Explain the Traffic –Related Attributes?**
- 4. Explain the GFR Traffic Management?**
- 5. Describe in detail about requirements for ATM Traffic and Congestion Control?**

## **UNIT-4(INTEGRATED &DIFFERENTIATED SERVICES)**

### **PART-A**

**1.What are the categories of traffic on a network?**

- i.Elastic
- ii.Inelastic

**2.Mention the common applications of elastic traffic?**

- i. File Transfer Protocol
- ii. Electronic Mail
- iii.Remote Login
- iv.Network management
- v.Web Access

**3.What are the requirements or inelastic traffic?**

- i.Throughput
- ii.delay
- iii.Jittar
- iv.Packet Loss

**4.Wat is the purpose of ISA approach?**

The purpose of ISA is to enable the provision of QOS support over IP based Internets.The central design issue for ISA is to share the available capacity in times of congestion.

**5.Mention two mechanism of routers?**

- i.Routing Algorithm

ii. Packet Discard

**6. What are the functions of ISA to manage congestion and provide QOS Transport**

- i. Admission Control
- ii. Routing algorithm
- iii. Queuing discipline
- iv. Discard policy

**7. What are the three categories of services?**

- i. guaranteed
- ii. controlled load
- iii. best effort

**8. In which fashion the queues are serviced in Fair Queuing and how?**

- i. Each incoming packet is placed in the appropriate queue.
- ii. The queues are serviced in round robin fashion.

**9. Why BRFQ is designed and how it is implemented?**

BRFQ is designed to emulate a bit by bit round robin discipline. It is implemented by computing virtual starting and finishing times on the fly as if PS were running.

**10. What are two drawbacks of FIFO queuing discipline?**

- i. No special treatment is given to packets from flows that are of higher priority or are more delay sensitive.
- ii. If a number of smaller packets are queued behind a long packet, then FIFO queuing results in a larger average delay per packet than if the shorter packets were transmitted before the longer packet

**11. What are the design goals of RED algorithm?**

- i. congestion avoidance
- ii. global synchronization avoidance

- iii.avoidance of bias against bursty traffic
- iv.bound on average queue length

**12.What are the he elements of traffic conditioning function?**

- i.Classifier
- ii.Meter
- iii.Marker
- iv.Shaper/Dropper

**13.What are the two types of Per HOP behavior?**

- i.Expedited forwarding PHB
- ii.Assured forwarding PHB

**14.What are the advantages of assured forwarding PHB?**

- i.simplicity
- ii.Little work is required by the interval nodes. Marking of the traffic at the boundary nodes based on traffic profile provides levels of service to different classes.

**15.What are the advantages of fair queuing?**

- i.Each busy flow gets to send exactly one packet per cycle.
- ii.Load balancing among the various flows.

**16.Define DS boundary node?**

A DS node that connects one DS domain to the node in another domain.

**17.Define DS interior node?**

A node in DS domain which is not the boundary node is called th e DS interior node.

**18.What is meant by guaranteed service?**

Flows that are reserving resources are provided with guaranteed service.The service provides assured capacity levels.

**19. What is meant by differentiated service?**

- i. It does not attempt to view the total traffic in demand in integrated sense.
- ii. It does not reserve network capacity in advance.
- iii. It provides different levels of QOS to different traffic flows.

**20. What is meant by integrated services?**

The IS provider,

- i. views the total current traffic demand
- ii. limits the demands with respect to the current capacity handled by the network
- iii. reserve resources within the domain to provide a particular QOS guaranteed .

**PART-B**

**1. Explain in detail about RED algorithm ?**

**2. Explain in detail about integrated services architecture (ISA) and its task with neat diagram?**

**3.(a) Write short notes on services provided by ISA**

**(b) Write short notes on per hop behavior in DS?**

**4. Explain the various queuing discipline and its limitations?**

**5. Explain in detail about the differentiated services(DS)?**

## **UNIT-5(PROTOCOLS FOR QOS SUPPORT)**

### **PART-A**

#### **1.What are the routers can do on the basis of QOS?**

- i. Use of queue discipline that gives preference to packets on the basis of QOS
- ii.Select among alternate routers on the basis of QOS characteristics of each path.
- iii.Invoke QOS treatment in the sub network of the next hop.

#### **2.Define RSVP?**

As the route change,reservation along the routes must also change the protocol for making resource reservation in the internet is called Resource Reservation Protocol

#### **3.What is meant by soft state concept in RSVP?**

RSVP use connectionless approach,each intermediate router maintain state information about nature of flow , that will be refreshed by end system at predetermined amount of time.

#### **4.What are the three concepts relating to data flows which forms the basis of RSVP operation?**

- i. Session
- ii. Flow specification
- iii. Filter specification

#### **5.Define session in RSVP?**

Once a reservation is made at a router by a particular destination , the router considers this as a session and allocates resources for the life of that session.

Session is defined by,

Session: Destination IP address

IP protocol identifier

Destination port

### **6. Define the flow specification in RSVP?**

The flow specification of RSVP specifies a desired QOS and is used to set parameters in a node's packet scheduler.

Flow spec is defined by,

*Flow spec* : Service class

R spec

T spec

### **7. Define filter specification in RSVP?**

Filter spec in RSVP defines the set of packets or flow , for which a reservation is requested.

Filter spec is defined by,

*Filter spec*: Source address

UDP/TCP source port

### **8. What are the two reservation styles?**

i. Reservation attribute

ii. Sender selection

### **9. What are the two message types used by RSVP for protocol mechanism?**

i. RESV

ii. Path are the message types

### **10. Define traffic engineering?**

The ability to define routes dynamically plan resource commitments on the basis of known demand , and optimize. Network utilization is referred to as traffic engineering.

### **11. Define Label swapping in MPLS?**

The basic operation of looking up an incoming label to determine the outgoing label and forwarding is called Label swapping.

**12. What is the purpose of time to live field in label format?**

The value of this field is decremented at each router and the packet is dropped if the count falls to zero.

**13. What is meant by integrated layer processing in RTP?**

In TCP/IP each layer processed sequentially, where as in integrated layer processing , adjacent layers are tightly coupled and they function parallaly.

**14. What is Labelled Swithched Routers(LSR)?**

An MPLS network or Internet consists of a set of nodes is called LSR, cable of switching and routing packets on the basis of which a label can be appended to each packet.

**15. What are the two options supported by MPLS?**

- i. Hop by hop routing
- ii . Explicit Routing

**16. Define route selection?**

It refers to the selection of an LSP for a particular LPC

**17. What are the functions performed by real time transport control protocol (RTCP)?**

- i)Quality of service and congestion control
- ii)Identification
- iii)Session size estimation and scaling
- iv)Session control

**18. What is a Good Bye(BYE)?**

The BYE packet indicates that one or more sources are longer active. This confirms to receivers that a prolonged silence is due to departure rather than network failure. The format consists of a 32-bit header followed by more source identifiers.

**19. What is meant by label merging?**

The replacement of multiple incoming labels for a particular forward equivalent class with a single outgoing label is called label merging.

**20. What is meant by frame merging?**

Label merging, when it is applied to operation over frame based media, then it is called frame merging.

**PART-B**

- 1. Explain the design goals, and characteristic of (RSVP) Resource Reservation Protocol?**
- 2. Explain the reservation types of RSVP in detail?**
- 3. Explain in detail about RTP data transfer protocol?**
- 4. Explain in detail about RTP control protocol and RTCP packets?**
- 5. (a) Explain the label stacking in MPLS and also label format and placement in MPLS?  
(b) Explain the route selection in MPLS?**

